

Automatic Bagging System PolyStar™



Standard Features:

- Two bag stations for higher speed and improved productivity
- Filling spout moves up and down for fast filling and minimal dusting
- Total bag top control, automatic reforming of bags
- 3-5 minute tool-less changeover
- Allen-Bradley PLC controlled
- Handles most paper, polyethylene, and woven bags
- High capacity bag magazine
- Automatic discharge of rejected bags

Barry-Wehmiller

Automatic Bagging System PolyStar™

Thiele Technologies' Series 7115XC Automatic Open-Mouth Bagger is a simple, reliable, highly accurate system for bagging free-flowing products in 20 to 100 lb. paper, poly, or woven polypropylene bags at speeds of up to 20 bags per minute.

The simple in-line design provides total bag control throughout the placement, opening, filling, and reforming operation. Spillage is virtually eliminated, maintenance is simple, and changeovers take only minutes without tools. Even dusty products are not a problem. The system's specialized "duck bill" filling spout moves into the bag prior to filling, which reduces blow-back and dusting.

A unified mechanical drive creates smooth and efficient machine operation, while in-line bag handling with total bag top control allows precision bag closing

and sealing. In addition, the PolyStar eliminates spillage, reduces downtime, allows easier troubleshooting, and minimizes dusting for greater productivity.

The PolyStar offers the large bag industry the production-enhancing features formerly found only on packaging systems for smaller bags.

This makes the PolyStar idea for applications where speed and line efficiency are critical. The feed, sugar, salt, seed, fertilizer, rice, and petro-chemical resin industries are just a few of the many industries that will benefit from the PolyStar.

With the proven success of Thiele's two-spout system in its UltraStar high-speed bagging system, the PolyStar is sure to have a major impact on the marketplace.

Specifications

PRODUCTION SPEED

Up to 15 bags per minute

BAG SIZES

Face Width	14" to 23" (355 to 585 mm)
Length PBOM	21" to 41" (533 to 1041 mm)
SOM	20" to 40" (508 to 1016 mm)

ELECTRICAL REQUIREMENTS

Input Power:	230/460 volt, 3 phase, 60 hz
Control Circuit:	115 volt, 1 phase, 60 hz (from control trans former)
Current Draw:	230 volt (20 amps) 460 volt (10 amps)

AIR REQUIREMENTS

Operating Pressure	80 psi (5.4 atm)
Line Pressure	90 psi (6.1 atm)
Air Use Per Cycle	1.6 scf (45 liters) free air per cycle

APPROXIMATE SHIPPING WEIGHT

Bagger	2,500 lbs. (1134 kg)
Bag Magazine	300 lbs. (136 kg)
Closing Conveyor	300 lbs. (136 kg)

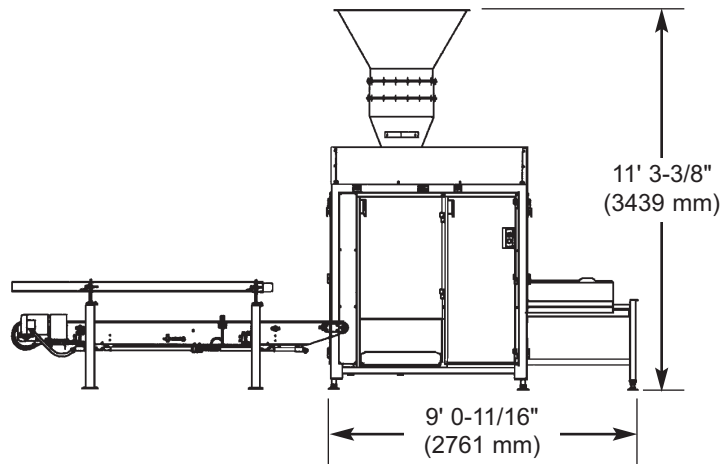
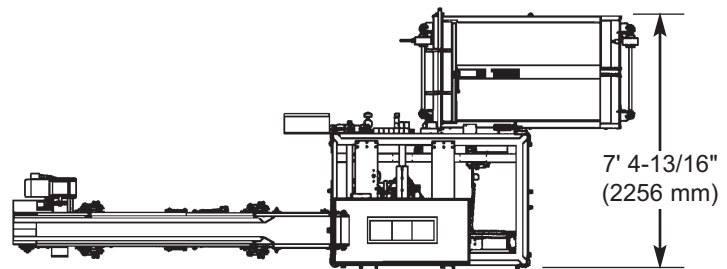

All sales are subject to our prevailing terms and conditions. Illustrations and specifications are subject to change without notice. Machines shown without guards are for illustrative purposes only. Guards are supplied and must be in place before installation.

Thiele Technologies, Inc.

315 27th Ave. N.E. • Minneapolis, MN 55418-2715 USA • 612/782-1200
www.thieletech.com sales@thieletech.com