

Aero-Seal® Bag Closer Series 4601



Standard Features:

- Hot air jets that reactivate adhesive without physical contact
- Crank style elevating mechanism that promotes fast height adjustment
- Sealed ball bearings that require no lubrication
- Corrosion resistant components
- Variable speed drive
- Minimal clean-out required

Options:

- Roll-type bag top printer
- Casters with locking pins
- Short auto infeed (Star Series)
- Long auto infeed (7115XC Series)

Barry-Wehmiller

ACCRAPLY

Barry-Wehmiller
Company



pneumatic
SCALE ANGELUS

Thiele
Technologies

DESIGN GROUP

Barry-Wehmiller
International Resources

Hayssen Sandiacre

Marquip Ward United

Fleetwood Goldco Wyard

Aero-Seal® Bag Closer Series 4601

The Thiele Series 4601 Aero-Seal® Bag Closer is designed to close polyethylene or foil lined, stepped-end, multi-wall bags after the bag has been filled with product. Once filled, heat bars seal the inner bag liner. Hot air then activates the pre-applied hot melt adhesive on the bag and folds over the top to seal the closure.

The 4601 incorporates a heat seal unit which is located at the entry end of the closer. It consists of spring-loaded heater bars that are designed to seal the polyethylene inner liner.

Operation

As the filled bag moves along a conveyor, the bag top is manually or automatically formed and fed into the entrance guide of the closer. V-belts then convey the bag top through the bag closer. The bag top first enters between the heater bars which seal an inner liner. Next the bag enters between the creasing rollers to set the fold line and to fold the bag top 90 degrees. The bag enters above the hot air nozzle where hot air, under regulated pressure and temperature, is forced against the adhesive to activate it. Finally, the bag top passes through a series of compression rollers to compress the fold and set the adhesive.

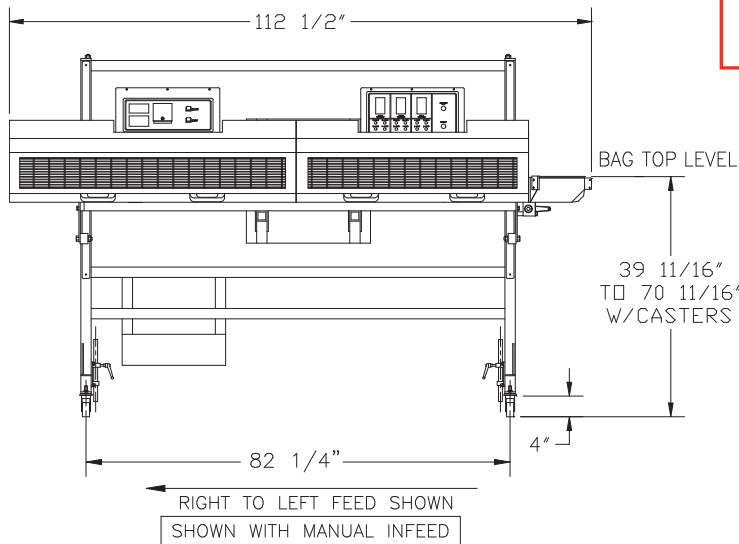

Specifications	
SPEED	
23 ft. to 43 ft. (7 m to 13 m) per minute. Actual maximum sealing speed may be less than that stated due to bag style, bag adhesive type, flap size, ambient temperature, and sealer heater temperature.	
BAG CONSTRUCTION	
Pre-applied adhesive should consist of three or four lines, starting approximately 1/8" (3 mm) from the edge of bag top. Adhesive lines to be approximately 3/16" (4.8 mm) wide with center-to-center distance approximately 3/8" (9 mm), depending on dimension of the step.	
POWER REQUIREMENTS	
Input Power	240 volts, 1 phase, 60 Hz*
Maximum Current Draw	240 volts (40 amps)
Motor	3/4 H.P.
*A 5 KVA transformer is required for control and heater circuit if input power is 480 volts	
AIR REQUIREMENTS	
Operating Pressure	5 to 8 psi (.34 to .54 Atm)
Line Pressure	60 psi (4.1 Atm) minimum
Maximum Free Air	8 cu. ft. (225 liters) free air per minute at 5 to 8 psi (.34 to 54 Atm)
DIMENSIONS	
Length	110.5" (2807 mm) includes 10.5" (266 mm) entry guide
Depth	44" (1112 mm)
Height	Overall 97" (2465 mm) maximum floor to bag top
Adjustable	35" to 66" (889 mm to 1677 mm)



Simple, tool-less clean-out

All sales are subject to our prevailing terms and conditions. Illustrations and specifications are subject to change without notice. Machines shown without guards are for illustrative purposes only. Guards are supplied and must be in place before operation.

Thiele Technologies, Inc.

HQ - Minneapolis, MN • Fergus Falls, MN • Fridley, MN • Reedley, CA
612/782-1200 218/739-3321 763/502-0000 559/638-8484

www.thieletech.com • sales@thieletech.com